

500  
szafka 50

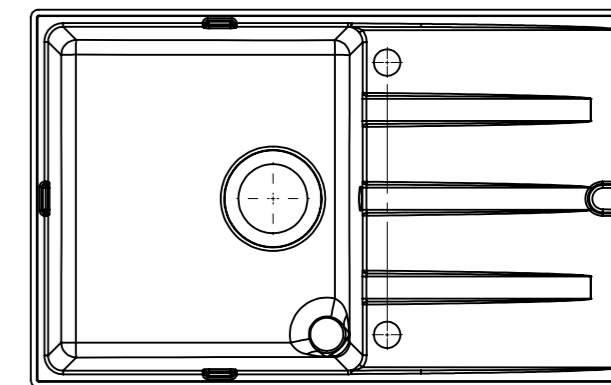

WIDOK D

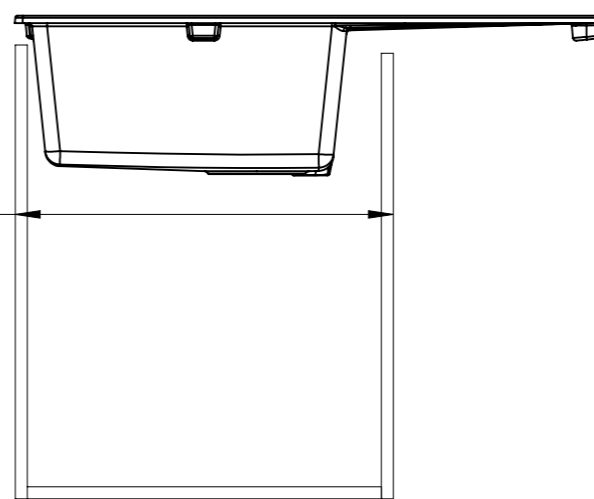
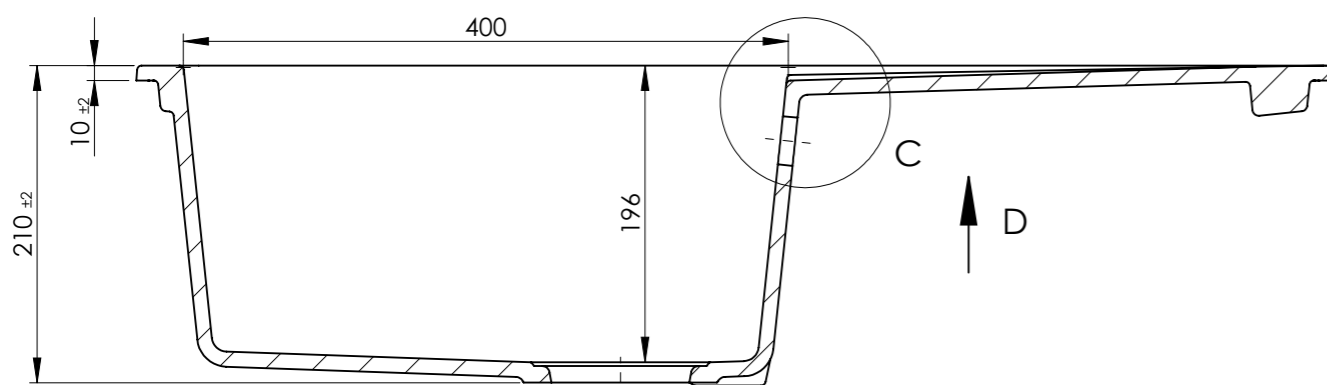

PRZEKRÓJ A-A  
SKALA 1 : 5

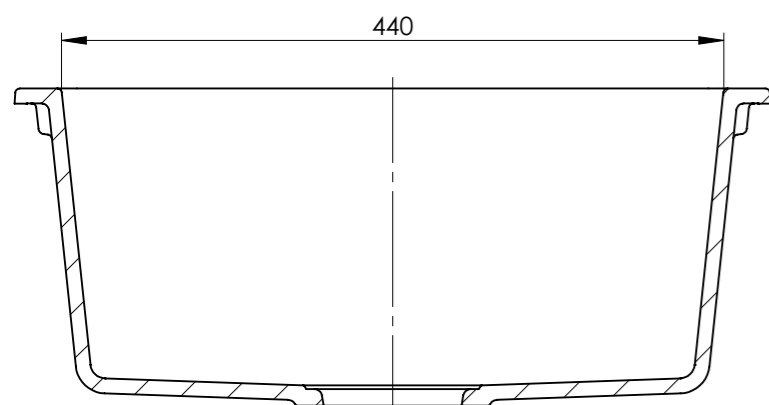

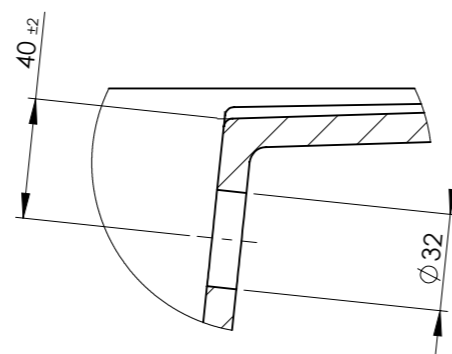

PRZEKRÓJ B-B  
SKALA 1 : 5

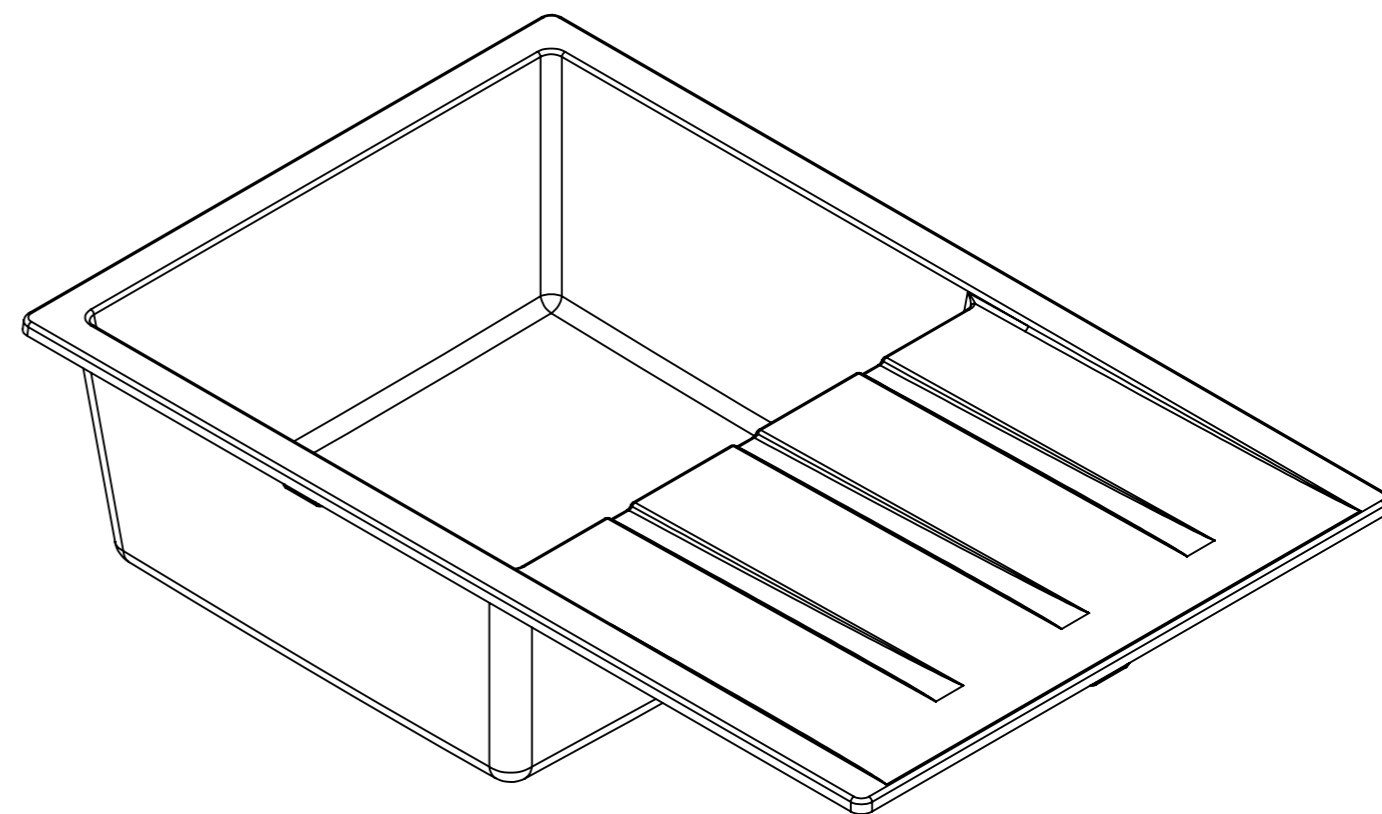

SZCZEGÓŁ C  
SKALA 2 : 5

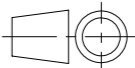

Nr zmiany	Ilość zmian	Podpis	Data	Materiał:				
				Kompozyt granitowy				
Konstruował	P.Mordaka	Podpis	2020-06-15	Norma:	PN-EN 695 PN-EN 13310 Wymiary nie tolerowane zgodnie z normą ISO 2768-1-v.			
Kreślił	N.Gąsiorowski	Podpis	2020-12-09		Objętość	Masa	Podziałka	Format
Sprawdził					6431 cm <sup>3</sup>	14 kg	1:10	A3
Zatwierdził				Nazwa rysunku:				
				Zakład Produkcyjny				
				WAGRAN Sp. z o.o. 97-200 Tomaszów Maz. ul. Spalska 103/105				
				Numer rysunku:				
				ZYEx11E - 003				